

# FLIP UP ANCHOR FOR OVERFLOW LANE LINES

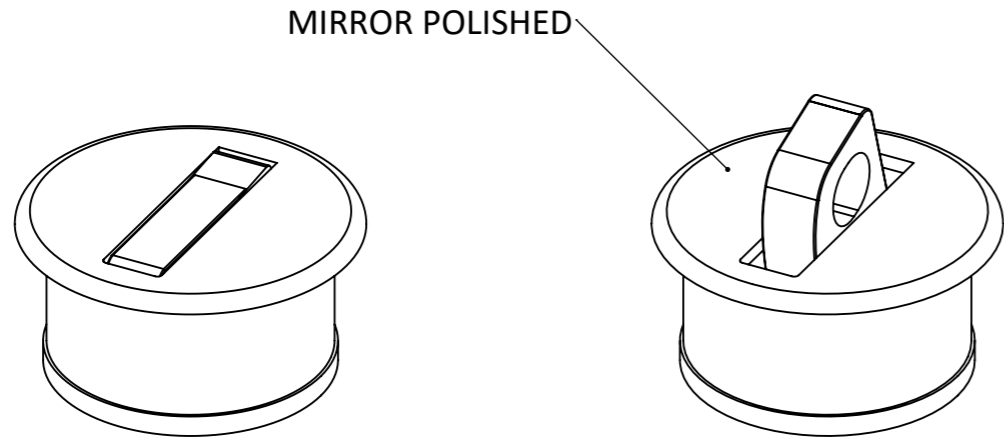

ISOMETRIC VIEW  
CLOSE AND OPEN

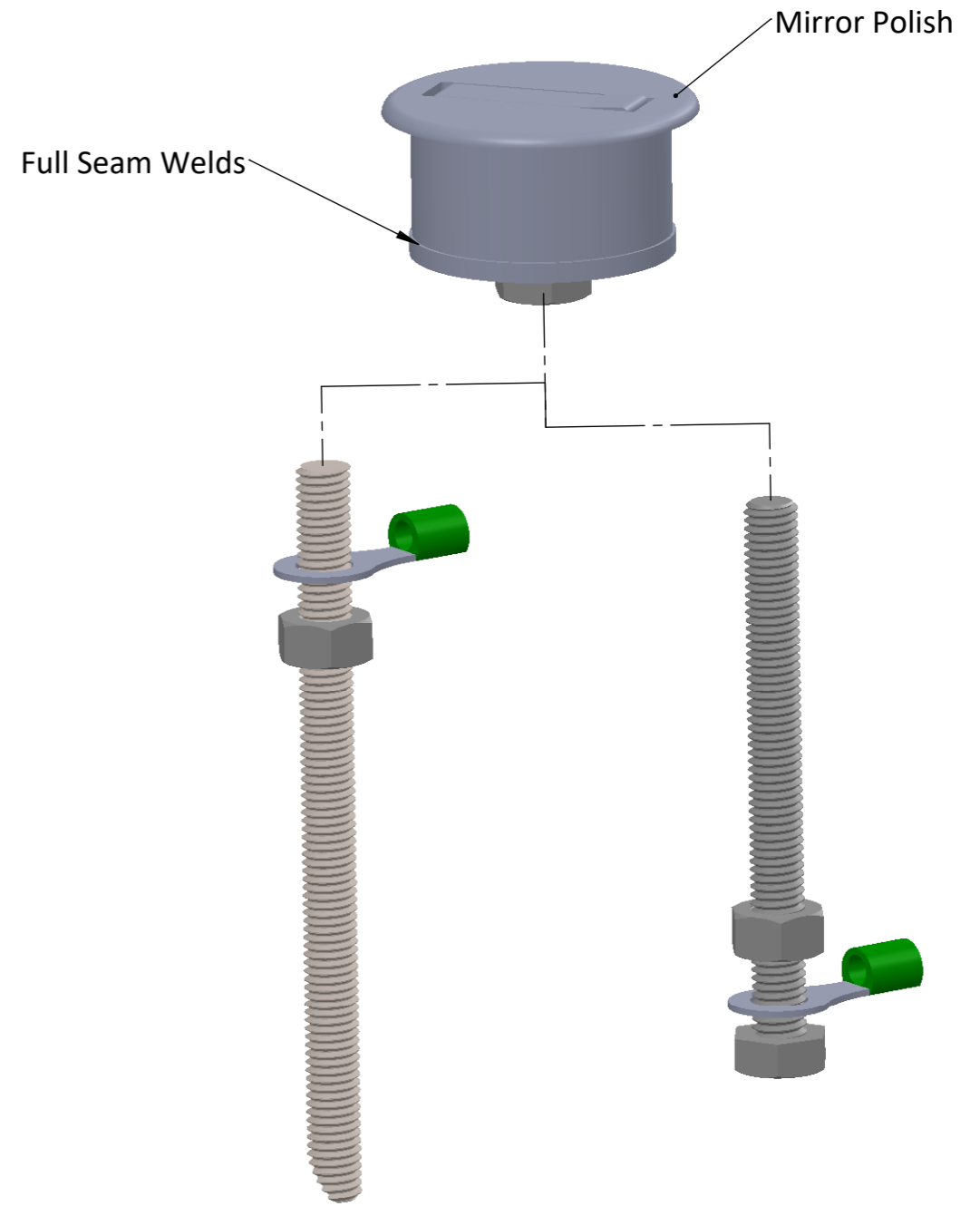
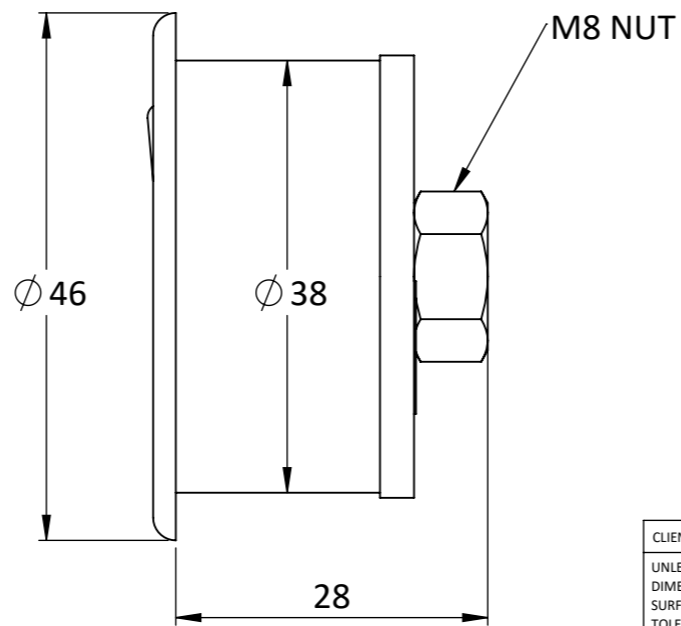
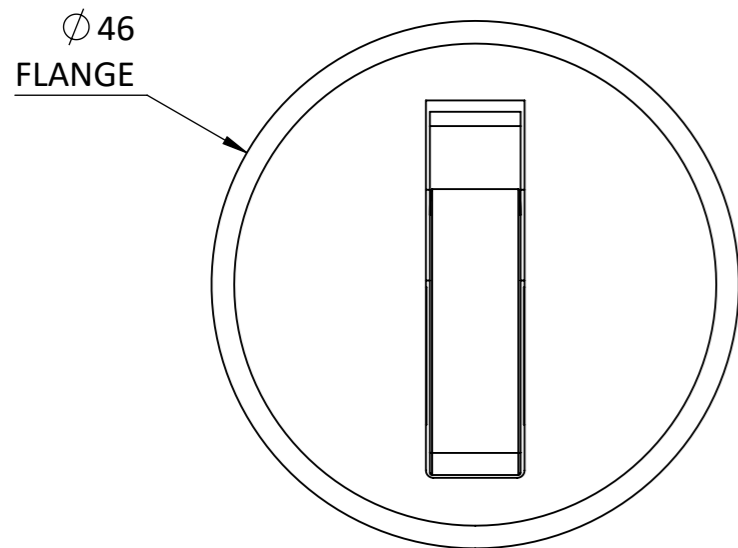

Multi Ways to Anchor and Earth in Epoxy

1. All threaded rod
2. Hex Head Bolt

**\*Hardware Not Included**

CLIENT: S.R.Smith AU		PROJECT: AU Internal Project		 Serious Equipment - Serious Fun - Access for All <b>SRSAustralia PTY LTD</b> 12 Enterprise Street, Richlands QLD 4077 PO Box 4416, Forest Lake QLD 4078 P +61 7 3812 2283   F +61 7 3812 1187			
UNLESS OTHERWISE SPECIFIED: DIMENSIONS ARE IN MILLIMETERS		FINISH: MIRROR POLISHED				TITLE: FLIP UP ANCHOR FOR OVERFLOW POOL	
SURFACE FINISH:		TOP SURFACE				17-61-35FA	
TOLERANCES: LINEAR: ±5mm ANGULAR: 1 deg		DRAWN: NM 15/04/2021		CHK'D: MF			
APPV'D:		DO NOT SCALE DRAWING		MATERIAL: 316 SS			
THE INFORMATION CONTAINED IN THIS DRAWING IS THE SOLE PROPERTY OF SRSMITH AUSTRALIA Pty Ltd. ANY REPRODUCTION IN PART OR IN WHOLE WITHOUT THE WRITTEN PERMISSION OF SRSMITH AUSTRALIA Pty Ltd IS PROHIBITED.		DWG NO. SRS-FUA-001		A3			
SCALE: 1:1		SHEET 1 OF 2		REVISION A			

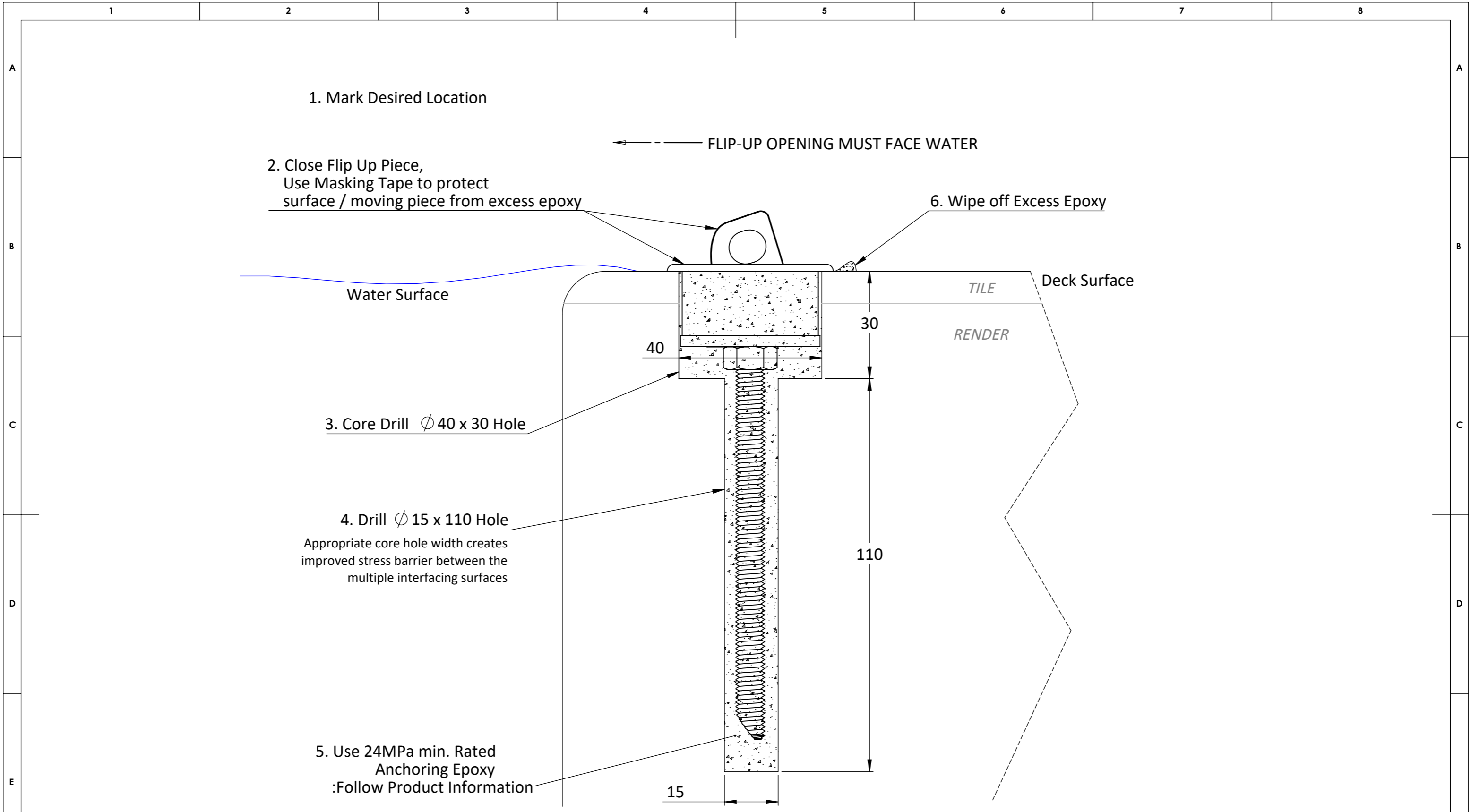

\*This is only guidelines for typical installation using SRSmith M8 Chemset Stud (sold separately)  
 Required size/tools may differ depending on the type of deck and surroundings

CLIENT: S.R.Smith AU		PROJECT: AU Internal Project		 Serious Equipment - Serious Fun - Access for All <b>SRSAustralia PTY LTD</b> 12 Enterprise Street, Richlands QLD 4077 PO Box 4416, Forest Lake QLD 4078 P +61 7 3812 2283   F +61 7 3812 1187	
UNLESS OTHERWISE SPECIFIED: DIMENSIONS ARE IN MILLIMETERS		FINISH: MIRROR POLISHED			
SURFACE FINISH:		TOP SURFACE			
TOLERANCES: LINEAR: ±5mm ANGULAR: 1 deg		NAME	SIGNATURE	DATE	LAST UPDATED
DRAWN: NM				15/04/2021	
CHK'D: MF					
APPV'D		DO NOT SCALE DRAWING			TITLE: FLIP UP ANCHOR FOR OVERFLOW POOL 17-61-35FA
THE INFORMATION CONTAINED IN THIS DRAWING IS THE SOLE PROPERTY OF SRSMITH AUSTRALIA Pty Ltd. ANY REPRODUCTION IN PART OR IN WHOLE WITHOUT THE WRITTEN PERMISSION OF SRSMITH AUSTRALIA Pty Ltd IS PROHIBITED.		MATERIAL: <b>316 SS</b>		DWG NO. <b>SRS-FUA-002</b>	
				SCALE:1:1	SHEET 2 OF 2
					A3 REVISION A